

## Installation Instructions

The AGDS-2 is a single or two channel gas detection system designed for use in boiler houses. Up to two low voltage detectors can be connected for the detection of natural gas, LPG or carbon monoxide.

In the event of a high alarm from one of the detectors, the system will isolate a connected control valve. Low alarm indication is also given

It is designed for use primarily in boiler house.



- Gas Detection . (one or two detectors)
- Natural gas, LPG and carbon monoxide
- Remote emergency stops
- BMS relay (high alarm status)
- 5 year warranty - 10 years when commissioned

### AGDS-2 features

Before commencing installation please familiarise yourself to the equipment by reading the comprehensive installation instructions. If in doubt then please call 0161 233 0600. Out of hours please call 07894 684080 or 07843 355163.

**It is a statutory requirement that this safety system is installed and commissioned to the satisfaction of the manufacturer.**

A commissioning certificate must be issued to the end user along with instructions for the operation of the equipment.

As the Manufacturer Medem UK should commission this safety system whereupon a commissioning report will be forwarded to the installing agent who should provide a copy to the end user.

At the point of our commissioning an individual serial number will be attached to the system along with a 24 help line number. Photos and all relevant information for the installation will then be stored on the Medem site database to be accessed in the event of a call on the 24 hour help line. The warranty period for the panel and sender unit will then be extended to Ten years.

The AGDS-2 system comprises of a mains powered main control panel capable of operating two sensors, either combustible or Carbon Monoxide gas or a mixture of both. The sensors are pre-calibrated by Medem (UK) Ltd such that they only require to be connected to the panel and functionally tested.

In the event of a high alarm from one of the sensors the system will isolate the gas supply by closing a connected electric control valve. Emergency stop buttons and Thermal Links can be fitted and a fire alarm can close the gas valve when connected to the panel.

### Control Panel

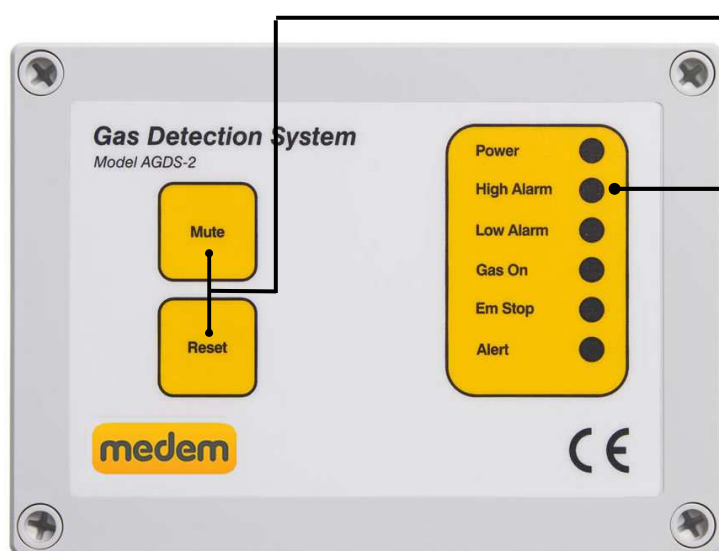

#### Panel Buttons:

Mute button  
Reset button

Press and hold the reset button (2's) when power is first applied to enable gas.

#### LED indications:

Power On	Green
High Alarm	Flashing red
High Alarm & Gas isolated	Permanent red
Low Alarm	Flashing red (every second)
Gas On	Yellow
EM Stop	Yellow
Alert	Yellow

### Low Voltage Gas Detectors

Combustible detectors are pre calibrated at 5% LEL (Pre alarm) and 10% LEL for the High alarm.  
Carbon Monoxide detectors are pre calibrated at 80ppm (pre alarm) and 100ppm for high alarm.

Connect a detector to either the "detector 1 terminals"(6&7) or "detector 2 terminals"(8&9), each detector has a rotary address selector switch (0-F) set to address 1 or 2 depending on which terminal has been used. Once connected and addressed you are required to enable the channel using the "channel enable switch"(12).

Each sensor unit has an LED which shows green when power is applied.

**Note:** There is a warm up period after initial power up of approximately 90 seconds. During this time the green LED will flash once per second and the output signal will be inhibited. This is to prevent spurious alarms. After the warm up period and on application of gas, the red LED will light when a high gas alarm level is reached.

A detector incorrectly addressed or a channel enabled when not in use will cause a "sensor Alert state" (yellow LED 20); which indicates that a detector is not being recognised on the current setting's - this can also be as a result of a connection issue with the wiring.

**When first powered or after a loss of power press and hold the reset button for 2 seconds to start the system and open the gas valve.**

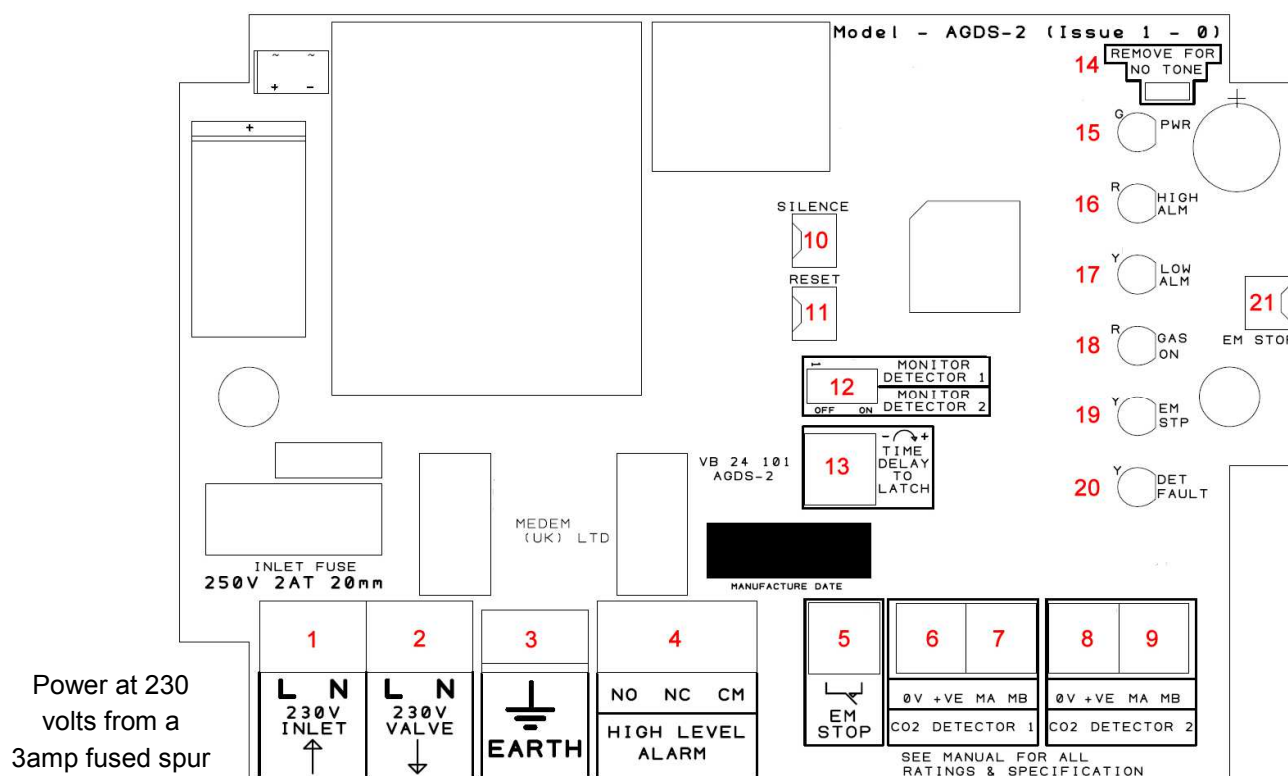

### Connections to panel: marked on board

1. Live & Neutral 230 volts supply from 3amp switched fuse spur
2. 230 volts out to gas solenoid valve (5amp relay)
3. Earth connection terminals
4. High Alarm BMS relay (potential free contact, mains rated, max load 5amp)
5. Remote emergency stop buttons SELV, multiple buttons connect in series (requires a N/C circuit)
6. Detector Channel One - Power connections for detectors, Methane, LPG, CO.
7. Detector Channel One - Comms connections for detectors, Methane, LPG, CO.
8. Detector Channel Two - Power connections for detectors, Methane, LPG, CO.
9. Detector Channel Two - Comms connections for detectors, Methane, LPG, CO.
10. Front Panel button connection - Mute
11. Front Panel button connection - Reset
12. Enable Detectors Channels - enable a channel when it has a detector connected.
13. High alarm time delay function - Controls the length of time between a High alarm and the closing of the gas valve
14. Jumper link to disable audible alarm sounder
15. Power Led - will illuminate when mains power is applied to the system
16. High Alarm LED - will illuminate when a detector enters high alarm (10% LEL for combustible 100ppm for CO)
17. Low Alarm LED - will illuminate when a detector enters low alarm (5% LEL for combustible 80ppm for CO)
18. Gas On LED - will illuminate to indicate when the gas valve is open - **press and hold the reset button to open valve**
19. EM Stop LED - will illuminate when any connected remote emergency stop buttons have been pressed
20. Alert LED - will illuminate if comm's to a detector are lost. (*Check detector address and channel enable switch settings*)
21. Front Panel button connection - Emergency Stop - not available on this model, (AGDS-2em only)

### Wiring information

#### Earth Connections not shown

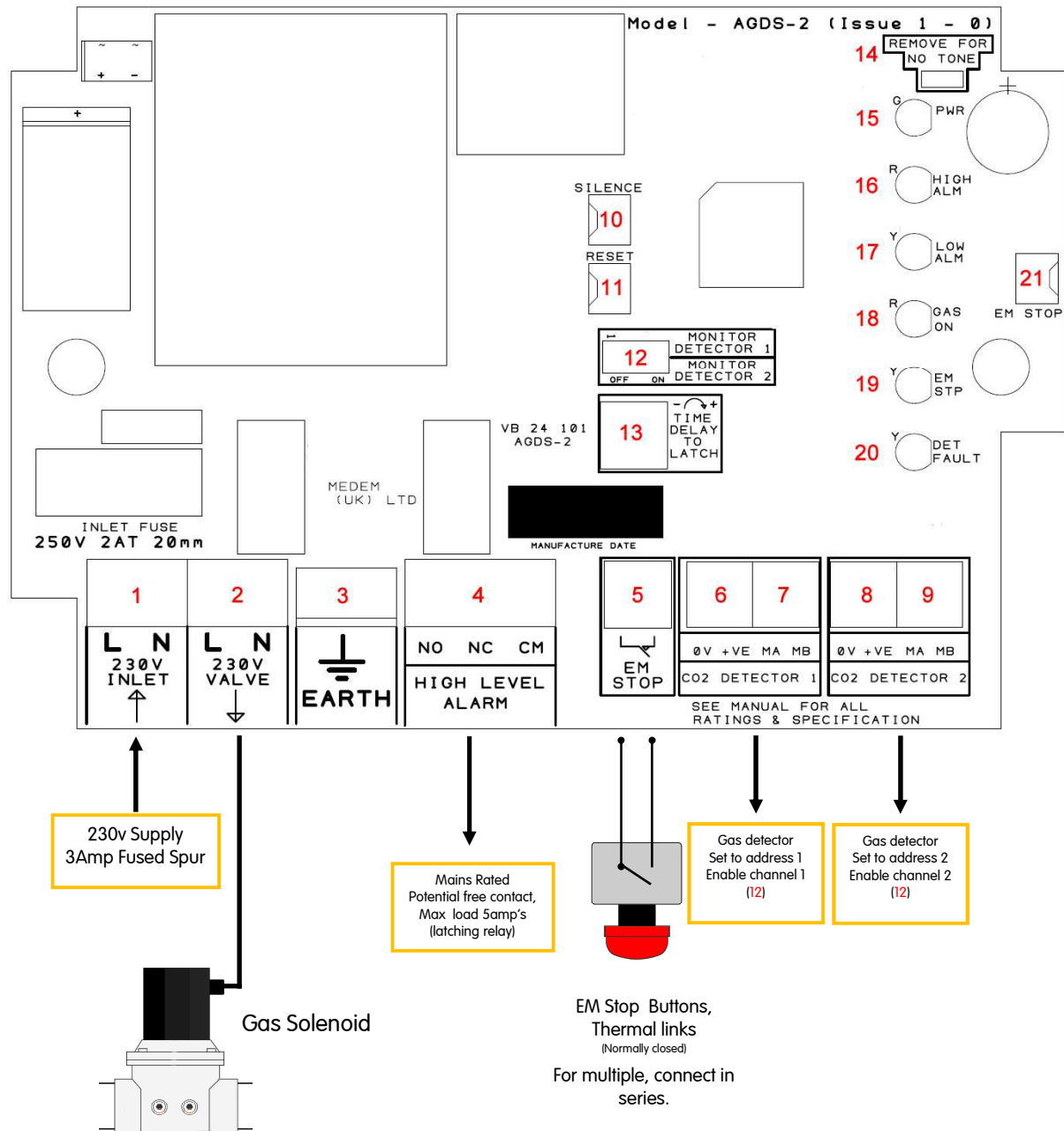

All current wiring regulations must be followed with reference to running low and mains voltage cables together.

The maximum cable length between a detector and the control panel should not exceed 100 metres, if the distance between the main panel and the detectors is greater than 20metres a 1mm screened cable must be used on the +VE, 0v terminals

Gas detectors, require a four core screened Belden type security cable or 600v rated BMS cable (max cable length of 100meters.)

Remote emergency stops and thermal links require a two core screened cable.

Warranty will be void if Fire Protection Cable or cable over 1mm dia. is used on the SELV side.

### Single Stop Buttons

Remote stop buttons can be connected to the panel terminal marked as "EM STOP" (number 6).

The remote buttons must be wired as shown in order to provide a "closed contact" for the control panel.

**If thermal links are to be installed these should be wired in series with the EM stop buttons**

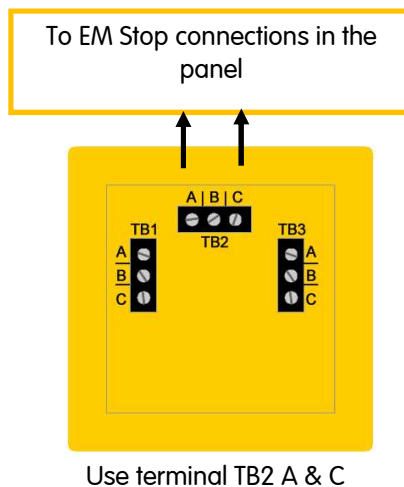

### Multiple Stop Buttons

Multiple stop buttons are wired in series.

If thermal links are to be installed these too should be wired in series with the EM stop buttons

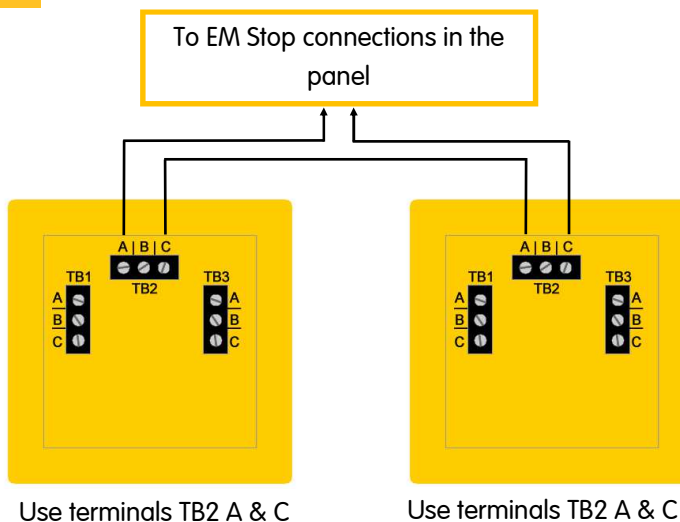

### Resetting (indicator bar)

The stop buttons supplied by Medem are of a "Push Glass, key resettable" style, when activated a yellow indicator bar will show and the unit will require resetting using the key provided.

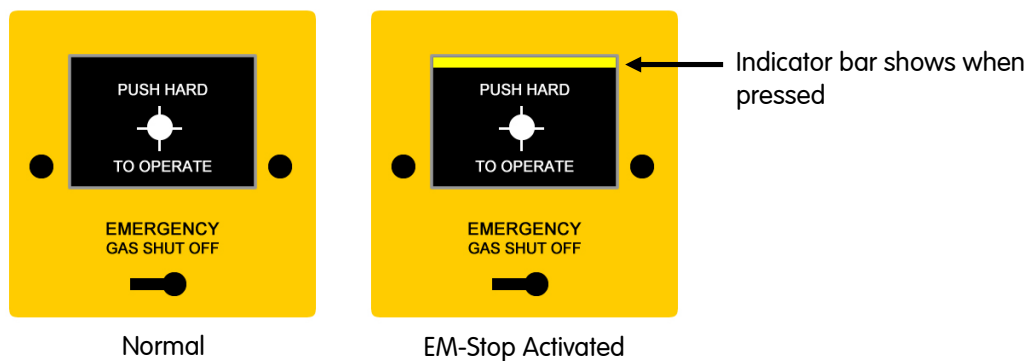

### Gas Detection

#### Gas Detectors

**IMPORTANT** - Gas Detectors should not be installed until all building, construction or painting work etc.. Is completed, as these works can effect the sensitivity and longevity of the detectors.



Ensure that the protective cover labels (**RED**) are removed only after the completion of all building work and the system has been commissioned by the Medem engineer.

The labels are required to be removed for the detectors to operate, but removal before the completion of works risks contaminating the sensor element.

The system is capable of operating a mix of up to 16 detectors (additional power pack may be required) of different types.

The detector types are:

- Carbon Monoxide.
- Combustible gases (Methane, Propane).

Detector location will vary dependant on the individual characteristics of the target gas that is being monitored for. See the gas detectors own instructions for more guidance.

### Connection and addressing

#### Address Selector

The selector must be set to either 1 or 2.

Detector 1 (**6&7**) = use address 1  
Detector 2 (**8&9**) = use address 2

You must then enable detector monitoring for 1 & 2 using dip switch (**12**)

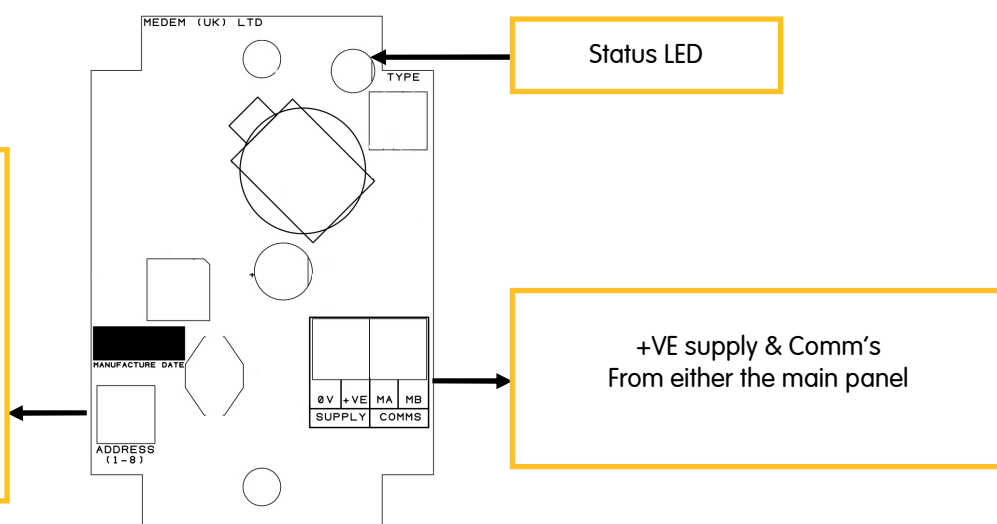

All current wiring regulations must be followed with reference to running low and mains voltage cables together.

The maximum cable length between a detector and the control panel should not exceed 100 metres, if the distance between the main panel and the detectors is greater than 20metres a 1mm screened cable must be used on the +VE, 0v terminals

Gas detectors, require a four core screened Belden type security cable or 600v rated BMS cable (max cable length of 100meters.)

Remote emergency stops and thermal links require a two core screened cable.

Warranty will be void if Fire Protection Cable or cable over 1mm dia. is used on the SELV side.

## Detector Indications

Each detector has its own Bi-Colour LED which is used to indicate the status of that detector.

Not Lit:	No power/comm's. These are four wire units and all connections are required, check the polarity of both the power and the comm's (MA/MB) terminals are correct. Check the detector is address to the correct channel and the channel has been enabled using switch (12)
Flashing Green:	Detector is warming up, the detectors will flash green on power up for 90 seconds while the sensor elements stabilize. The system will ignore any detectors while flashing.
Solid Green:	Detector is powered and active.
Flashing Red:	Low level alarm. All detectors have both a low and high level alarm, low level alarms serve as a warning that an unsafe condition may be building and gives chance to intervene before loss of gas service.
Solid Red	High level alarm. An unsafe level of the target gas has been reached and the system will isolate the gas supply. The cause of the alarm will require identifying and resolving before the gas supply can be re-established.

After installation a simple bump test can be performed by using an appropriate level test gas in order to check operation. Full testing and calibration checking takes place during a Medem commissioning.

## Detector Location information

Detector location will vary dependant on the individual characteristics of the target gas that is being monitored for. The descriptions below describe the position for each detector after considering these characteristics.

For proper function care must be taken not to site a detector in a "dead space" or in the flow of any ventilation.

### **Natural Gas/Methane**

Natural gas detectors should be mounted at high level on a wall approximately 150mm from the ceiling height and avoiding corners and potential dead air areas.

Natural gas detectors should not be mounted below the height of the top of a doorway for example. This is because as the gas is slightly lighter than air it will rise filling the room from the ceiling down and will spill through the top of a door opening into the next room. If the detectors are mounted below this height then it will take longer for the gas to reach the detector.

### **LPG /Propane**

LPG gas is heavier than air so detectors need to be mounted at low level 100mm from the floor, consideration should be given to any potential mopping or wet floor height.

### **Carbon Monoxide**

Carbon Monoxide is similarly weighted to air so detectors should be mounted between 1 to 2 meters from the floor.

### **Carbon Dioxide**

Carbon Dioxide detectors should be installed so they monitor the general level of CO2 within the area. They should be mounted above standing head height and between 1m and 3m from the potential source. Care should be taken so they are not located close to the edge of a canopy or in direct flow of the supply or extract ventilation.

*For additional information or guidance on site specific requirements please don't hesitate to contact us.*

Medem (UK) Limited  
Project House  
19 Dallimore Road  
Manchester  
M23 9NX

Tel: (0) 161 233 0600  
Fax: (0) 161 233 0601  
Web: [www.medem.co.uk](http://www.medem.co.uk)  
E-mail: [sales@medem.co.uk](mailto:sales@medem.co.uk)

## Medem UK Warranty Terms & Conditions

1. The warranty is a parts warranty and Medem UK Ltd will not cover or accept any labour or other expenses that may be incurred in the process of changing faulty product.
2. All panels and sender units are covered by a five year warranty.
3. Gas detector units and other remote detectors carry a two year warranty. Installation of the detectors should not be undertaken until all building and construction work is completed.
4. Gas solenoid valves carry the original manufacturers warranty, though as the supplier Medem UK will exchange faulty valves for return to the manufacturer.
5. Where a Medem UK engineer (or another company appointed by Medem UK) commission and installed system then that system will carry a ten year warranty. This applies to the main panel and the sender unit. At the time of commissioning a security label with a serial number will be attached to the main panel box. photographs and a comprehensive record of the installation will be held by Medem UK.
6. Where a warranty claim is made then, where appropriate, a written order to attend site must be provided to Medem UK A cost for labour and travel to site will be prepared as a quote. The cost must be included in the order.
7. Where it is found that the installation and/or the quality of workmanship has contributed to or wholly caused the failure of the product then we reserve the right to charge the whole or a proportion of the cost of the faulty item.



It is essential that the installation is carried out in the order given below to ensure the correct operation of the system.

First read the system description sheet before following the instructions below

1. Connect the Control valve twin & earth to the marked terminals.
2. Connect BMS, beacons, sounders etc to the relay outputs.
3. Connect any additional EM stop buttons and thermal links in series to the terminals marked "EM STOP".
4. Each detector has a rotary address switch and each switch should be set to address's "1" or "2", then connected to the appropriate gas detector terminal marked "detector 1" or "detector 2" on the panel.
5. Enable the detector channels (1 or 2) as being used by with switch (12) Connect the 3 amp fused spur 240 volt supply to marked terminals.
6. Once power is connected to the panel the detectors will flash the green LED's for 90 seconds after which the LED's will be on continuously.
7. At this point press the reset switch and the control valve will open and the system is now running.

Notes.

It is recommended that all systems are commissioned after installation by Medem UK. This will extend the warranty period from 5 years to 10 years and ensure the system is working as designed.  
Please see warranty conditions that came with the main panel

**Please do not hesitate to call for advice on the following numbers:  
0161 233 0600 office hours  
Or out of hours call:**